

Positive drive of products across conveyor transfers



FlexLink offers a range of inline pre-built driven conveyor transfers for the drive of products when feeding between conveyor drive and idler, conveyor drive and machine, and idler unit and machine.

The design allows positive transfer of products, ensuring there are no products stalling across conveyor transfers.

The unit is available in three different standard configurations and with two standard options – either belt or driven roller. It is supplied as a complete module that can be integrated into any line, new or existing.

Note

It is recommended that the transfer is fully guarded on line integration to ensure a safe design.

Standard features

- **Robust** – designed to operate within a production line without reducing the stability of the conveyor system
- **Clean** – clean design with minimal dust ingress or dirt build up areas.
- **Modular design** – allows quick changeover in event of routine maintenance or breakdown.
- **Simple installation** – mount to conveyor using standard fittings.

Technical specification

The conveyor transfers are compatible with the following conveyor systems: XL, X85, XH, XK, X180 and X300.

Drive options

The positive drive is given by two means:

- Option 1: driven belt on the transfer
- Option 2: driven roller design

Operating parameters

Max. conveyor speed	60 m/min
Max. product weight	
XL, X85	1,5 kg
XH, XK, X180, X300	3 kg

Operating environment

Temperature	10–35 °C
Relative humidity.....	60%

Not suitable for explosive environment or direct food contact.

Configurations

Configuration 1



A driven transfer from drive unit with a machine interface.

Configuration 3



A driven transfer from drive unit to idler inline.

Configuration 2

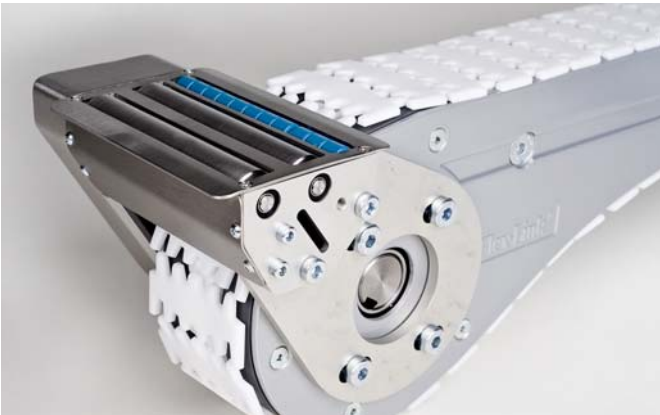

A driven transfer onto an idler from a machine interface.

Driven roller configurations

Driven rollers, XL

Drive unit – machine

XLEB HL/HR – Machine

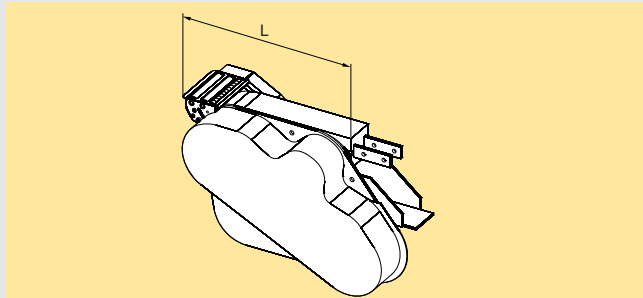

XLEB HL – Machine **8043382**
XLEB HR – Machine **8044301**
L = 354 mm

XLEB HLP/HRP – Machine

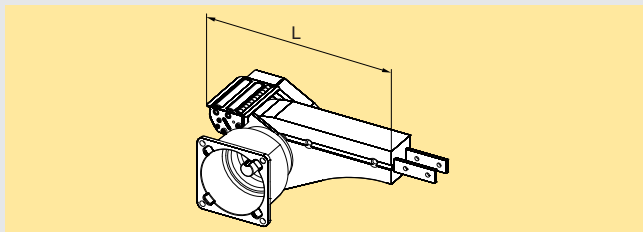

XLEB HLP – Machine **8043383**
XLEB HRP – Machine **8044302**
L = 354 mm

XLEB HNLP/HNRP – Machine

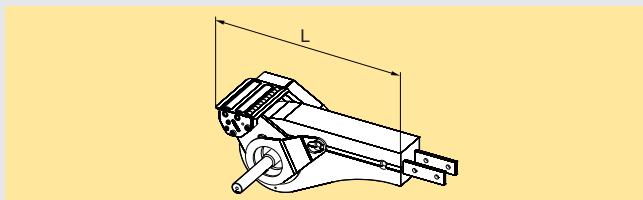

XLEB HNLP – Machine **8043721**
XLEB /HNRP – Machine **8044303**
L = 354 mm

Idler unit – machine

XLEJ 320 – Machine

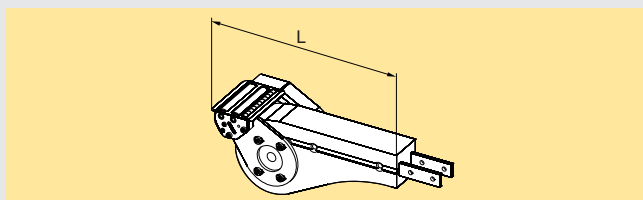

XLEJ 320 – Machine **8043384**
L = 354 mm

Drive unit – idler unit

XLEB HL/HR – XLEJ 320

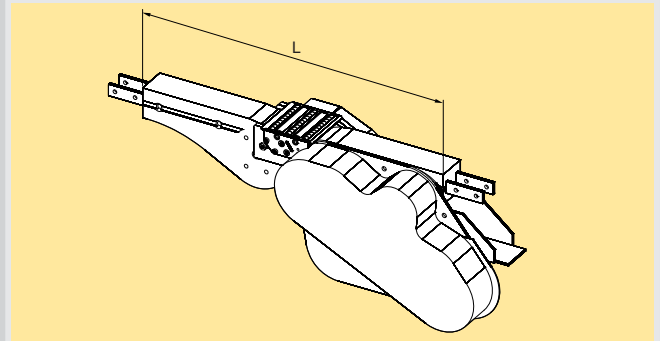

XLEB HL – XLEJ 320 **8043385**
XLEB HR – XLEJ 320 **8044304**
L = 656 mm

XLEB HLP/HRP – XLEJ 320

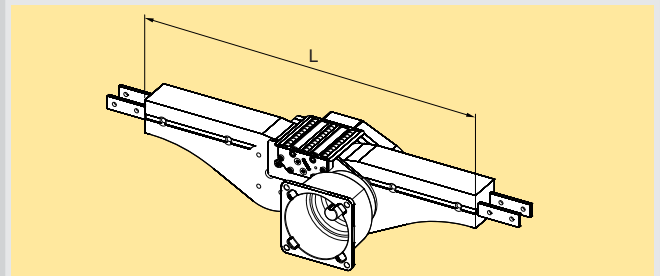

XLEB HLP – XLEJ 320 **8043386**
XLEB HRP – XLEJ 320 **8044305**
L = 656 mm

XLEB HNLP/HNRP – XLEJ 320

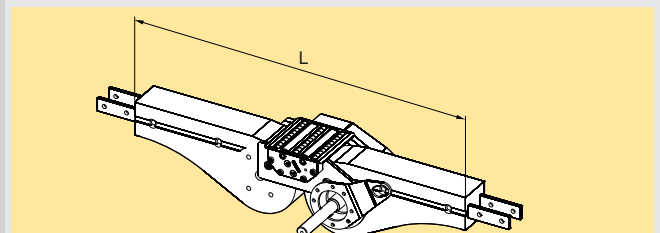

XLEB HNLP – XLEJ 320 **8043387**
XLEB HNRP – XLEJ 320 **8044306**
L = 656 mm

Driven rollers, X85

Drive unit – machine

XBEB A85 HL/HR – Machine

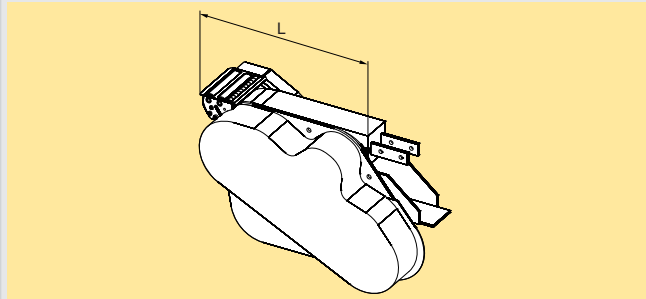

XBEB A85 HL – Machine **8043388**
XBEB A85 HR – Machine **8044307**
L = 354 mm

XBEB A85 HLP/HRP – Machine

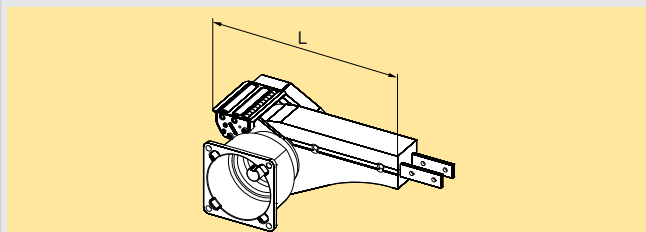

XBEB A85 HLP – Machine **8043389**
XBEB A85 HRP – Machine **8044308**
L = 354 mm

XBEB A85 HNLP/HNRP – Machine

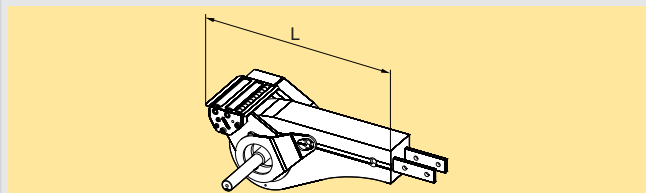

XBEB A85 HNLP – Machine **8043390**
XBEB A85 HNRP – Machine **8044309**
L = 354 mm

Idler unit – machine

XBEJ A85 – Machine

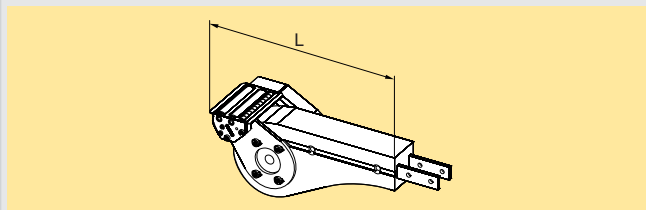

XBEJ A85 – Machine **8043391**
L = 354 mm

Drive unit – idler unit

XBEB A85 HL/HR – XBEJ A85

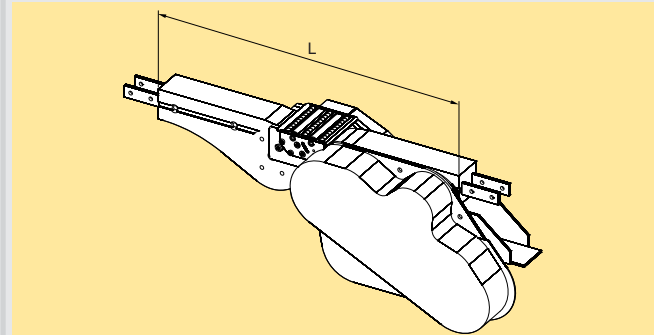

XBEB A85 HL – XBEJ A85 **8043392**
XBEB A85 HR – XBEJ A85 **8044310**
L = 656 mm

XBEB A85 HLP/HRP – XBEJ A85

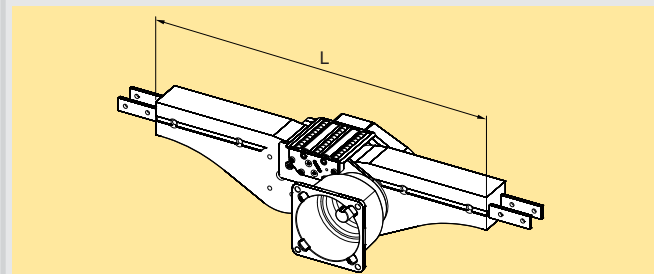

XBEB A85 HLP – XBEJ A85 **8043393**
XBEB A85 HRP – XBEJ A85 **8044311**
L = 656 mm

XBEB A85 HNLP/HNRP – XBEJ A85

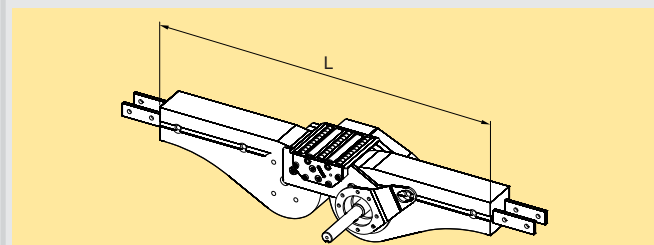

XBEB A85 HNLP – XBEJ A85 **8043394**
XBEB A85 HNRP – XBEJ A85 **8044312**
L = 656 mm

Driven rollers, XH

Drive unit – machine

XHEB HL/HR – Machine

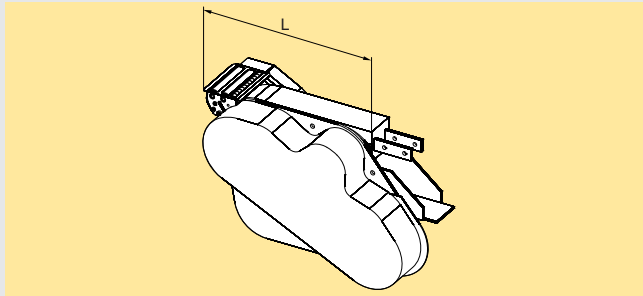

XHEB HL – Machine
XHEB HR – Machine
L = 354 mm

8043395
8044313

XHEB HLP/HRP – Machine

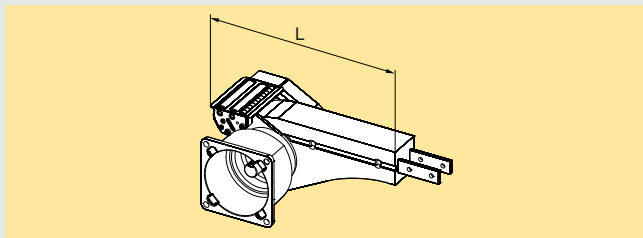

XHEB HLP – Machine
XHEB HRP – Machine
L = 354 mm

8043396
8044314

XHEB HNLP/HNRP – Machine

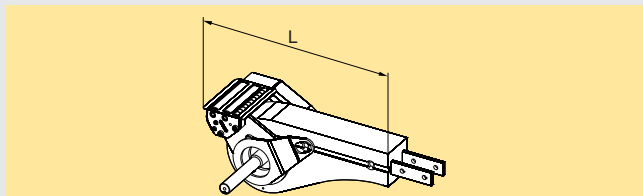

XHEB HNLP – Machine
XHEB HNRP – Machine
L = 354 mm

8043397
8044315

Idler unit – machine

XHEJ 325 – Machine

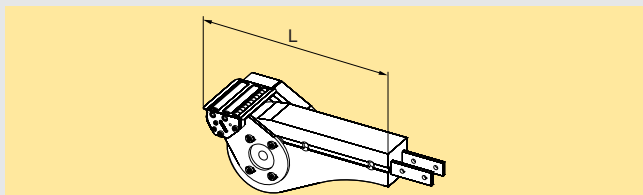

XHEJ 325 – Machine
L = 354 mm

8043398

Drive unit – idler unit

XHEB HL/HR – XHEJ 325

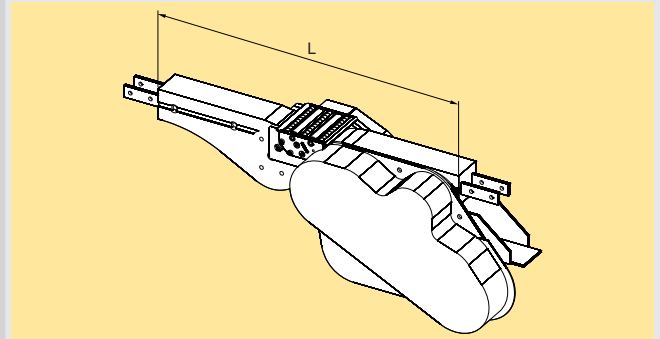

XHEB HL – XHEJ 325
XHEB HR – XHEJ 325
L = 656 mm

8043399
8044316

XHEB HLP/HRP – XHEJ 325

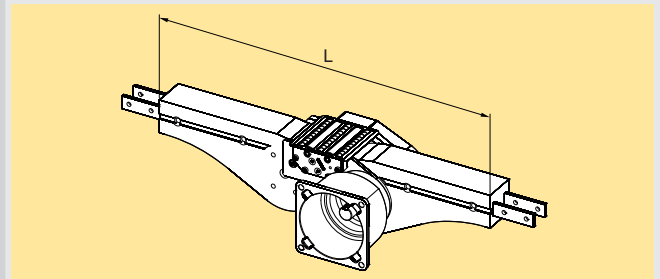

XHEB HLP – XHEJ 325
XHEB HRP – XHEJ 325
L = 656 mm

8043400
8044317

XHEB HNLP/HNRP – XHEJ 325

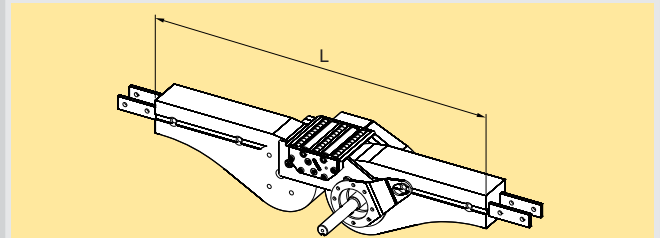

XHEB HNLP – XHEJ 325
XHEB HNRP – XHEJ 325
L = 656 mm

8043401
8044318

Driven rollers, XK

Drive unit – machine

XKEB HL/HR – Machine

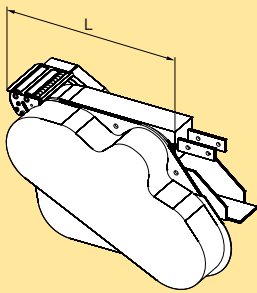

XKEB HL – Machine
XKEB HR – Machine
L = 354 mm

8043402
8044319

Drive unit – idler unit

XKEB HL/HR – XKEJ 350

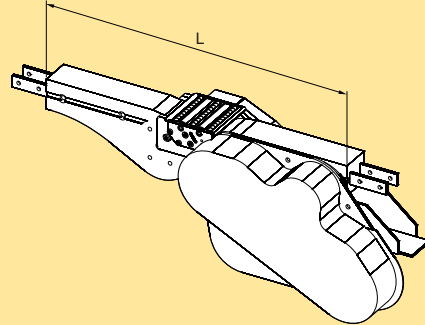

XKEB HL – XKEJ 350
XKEB HR – XKEJ 350
L = 656 mm

8043405
8044321

XKEB LP/RP – Machine

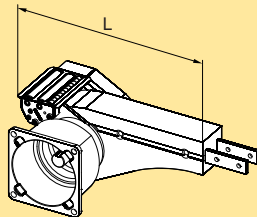

XKEB LP – Machine
XKEB RP – Machine
L = 354 mm

8043403
8044320

XKEB LP/RP – XKEJ 350

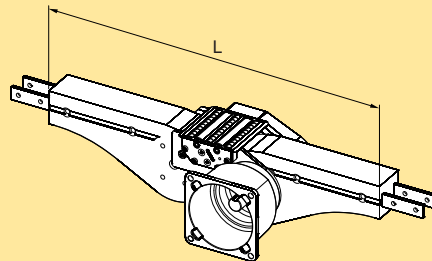

XKEB LP – XKEJ 350
XKEB RP – XKEJ 350
L = 656 mm

8043406
8044322

Idler unit – machine

XKEJ 350 – Machine

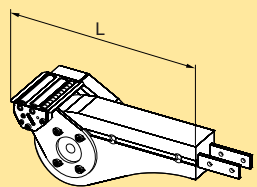

XKEJ 350 – Machine
L = 354 mm

8043404

Driven rollers, X180

Drive unit – machine

XBEB A180HLP/HRP – Machine

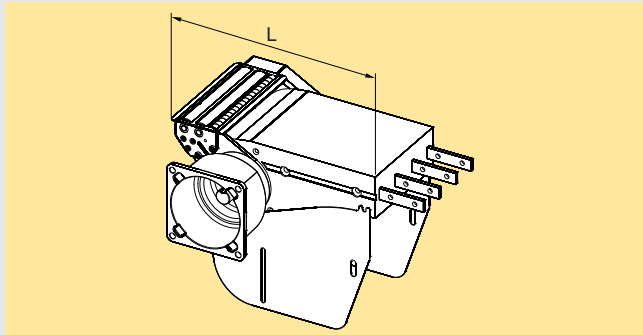

XBEB A180HLP – Machine
XBEB A180HRP – Machine
L = 366 mm

8043950
8044323

XBEB A180HNLP/HNRP – Machine

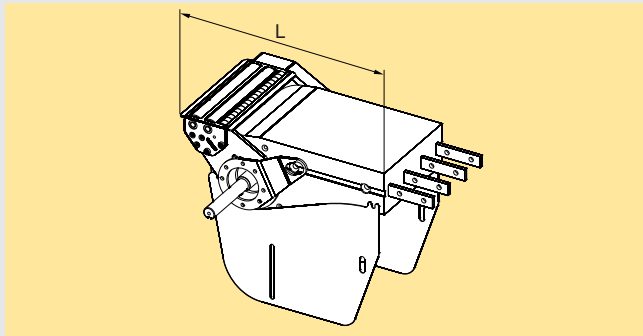

XBEB A180HNLP – Machine
XBEB A180HNRP – Machine
L = 366 mm

8043407
8044324

Idler unit – machine

XBEJ A180 – Machine

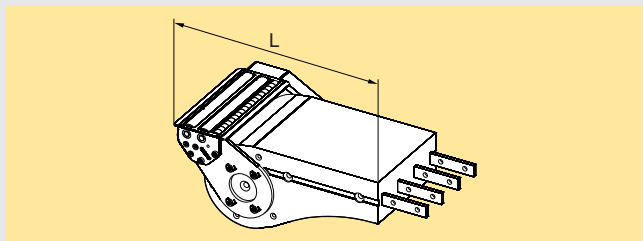

XBEJ A180 – Machine
L = 366 mm

8043411

Drive unit – idler unit

XBEB A180HLP/HRP – XBEJ A180

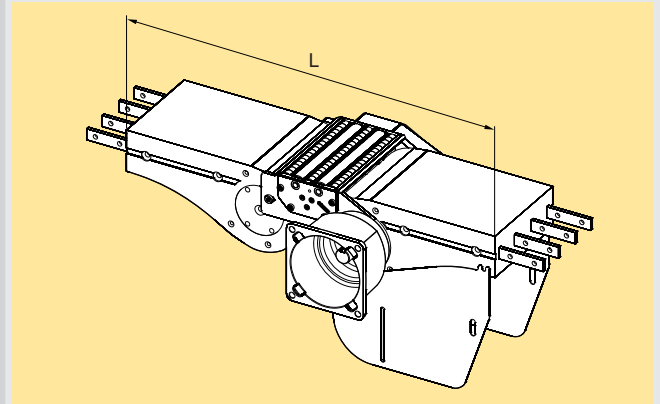

XBEB A180HLP – XBEJ A180
XBEB A180HRP – XBEJ A180
L = 670 mm

8043952
8044327

XBEB A180HNLP/HNRP – XBEJ A180

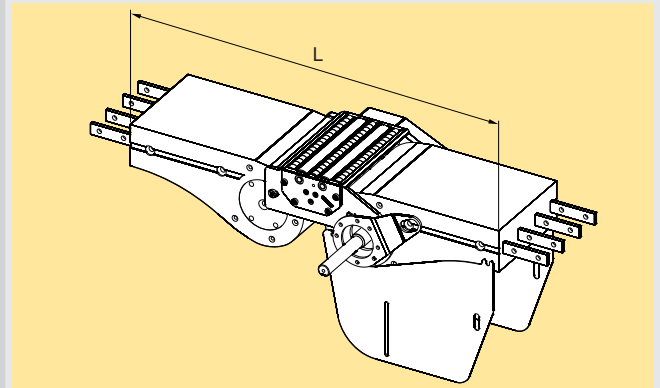

XBEB A180HNLP – XBEJ A180
XBEB A180HNRP – XBEJ A180
L = 670 mm

8043409
8044328

Driven rollers, X300

Drive unit – machine

XBEB A300HLP/HRP – Machine

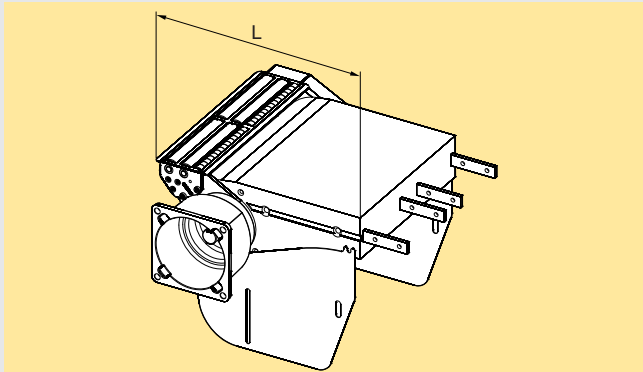

XBEB A300HLP – Machine
XBEB A300HRP – Machine
L = 366 mm

8043951
8044325

XBEB A300HNLP/HNRP – Machine

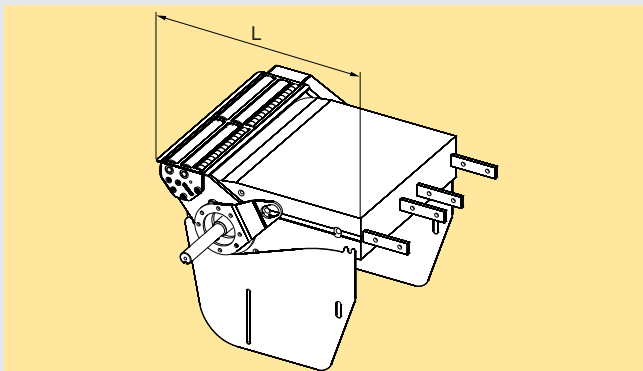

XBEB A300HNLP – Machine
XBEB A300HNRP – Machine
L = 366 mm

8043408
8044326

Idler unit – machine

XBEJ A300 – Machine

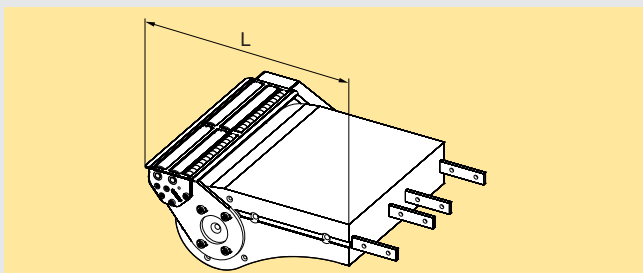

XBEJ A300 – Machine
L = 366 mm

8043412

Drive unit – idler unit

XBEB A300HLP/HRP – XBEJ A300

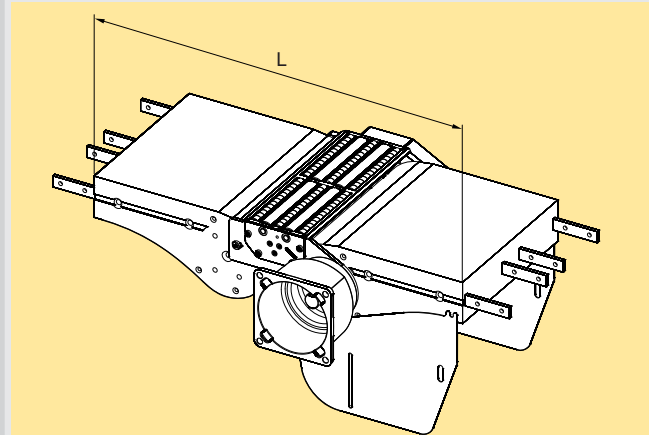

XBEB A300HLP – XBEJ A300
XBEB A300HRP – XBEJ A300
L = 670 mm

8043953
8044329

XBEB A300HNLP/HNRP – XBEJ A300

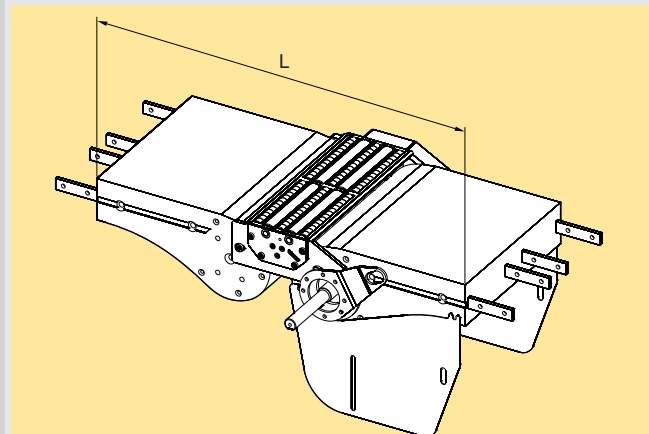

XBEB A300HNLP – XBEJ A300
XBEB A300HNRP – XBEJ A300
L = 670 mm

8043410
8044330

Driven belt

Driven belt, XL

Drive unit – machine

XLEB HL/HR – Machine

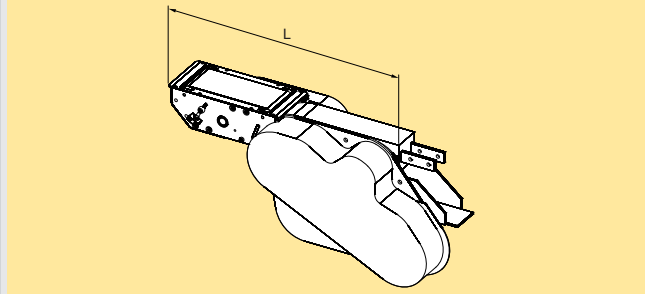

XLEB HL – Machine
XLEB HR – Machine
L = 544 mm

8043690
8044331

XLEB HLP/HRP – Machine

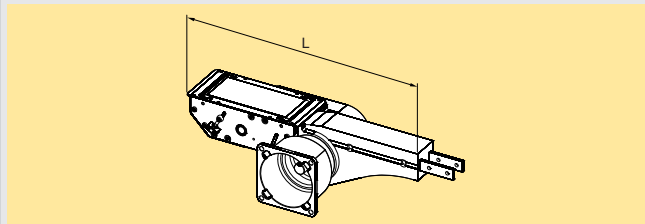

XLEB HLP – Machine
XLEB HRP – Machine
L = 544 mm

8043691
8044332

XLEB HNLP/HNRP – Machine

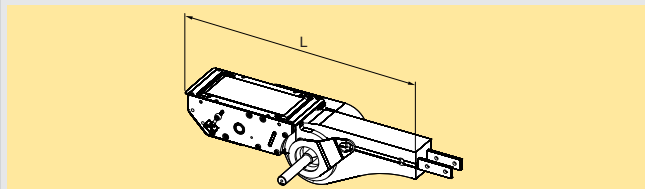

XLEB HNLP – Machine
XLEB HNRP – Machine
L = 544 mm

8043722
8044333

Idler unit – machine

XLEJ 320 – Machine

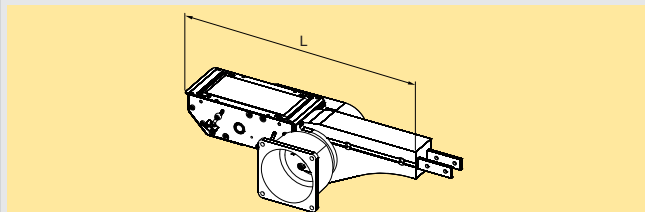

XLEJ 320 – Machine
L = 544 mm

8043692

Drive unit – idler unit

XLEB HL/HR – XLEJ 320

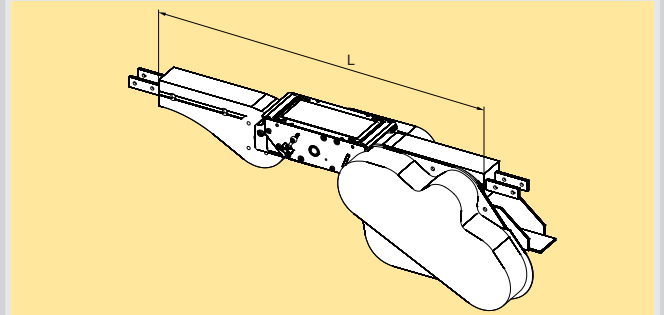

XLEB HL – XLEJ 320
XLEB HR – XLEJ 320
L = 818 mm

8043693
8044334

XLEB HLP/HRP – XLEJ 320

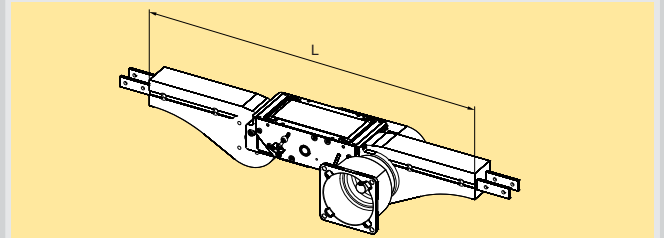

XLEB HLP – XLEJ 320
XLEB HRP – XLEJ 320
L = 818 mm

8043694
8044335

XLEB HNLP/HNRP – XLEJ 320

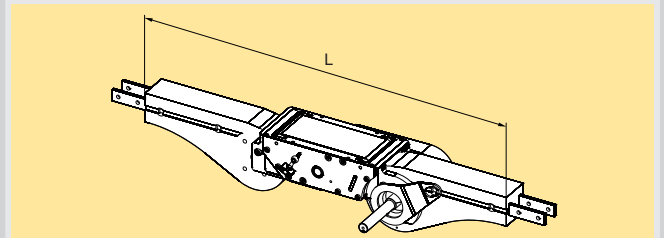

XLEB HNLP – XLEJ 320
XLEB HNRP – XLEJ 320
L = 818 mm

8043695
8044336

Driven belt, X85

Drive unit – machine

XBEB A85 HL/HR – Machine

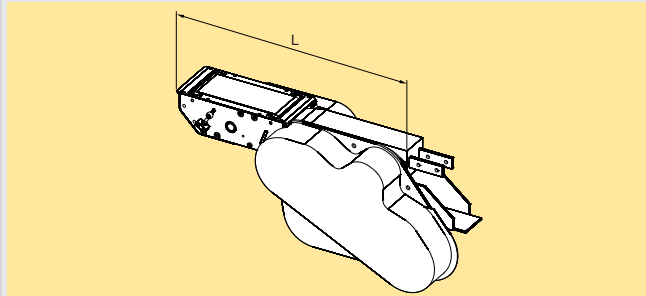

XBEB A85 HL – Machine **8043696**
XBEB A85 HR – Machine **8044337**
L = 544 mm

XBEB A85 HLP/HRP – Machine

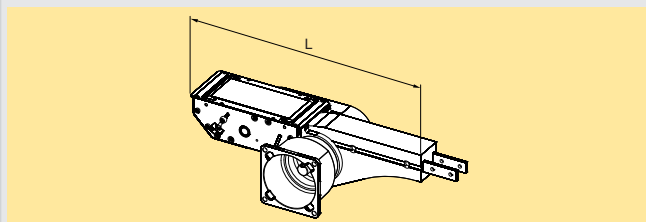

XBEB A85 HLP – Machine **8043697**
XBEB A85 HRP – Machine **8044338**
L = 544 mm

XBEB A85 HNLP/HNRP – Machine

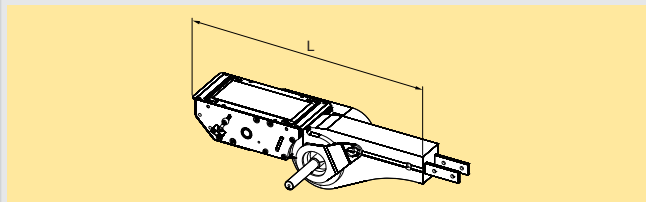

XBEB A85 HNLP – Machine **80433698**
XBEB A85 HNRP – Machine **80443339**
L = 544 mm

Idler unit – machine

XBEJ A85 – Machine

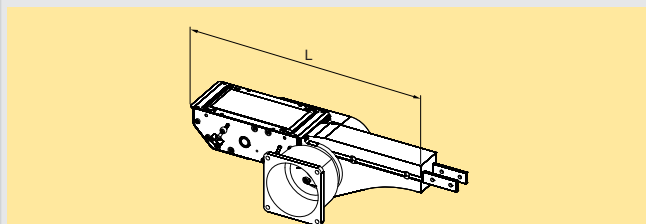

XBEJ A85 – Machine **8043699**
L = 544 mm

Drive unit – idler unit

XBEB A85 HL/HR – XBEJ A85

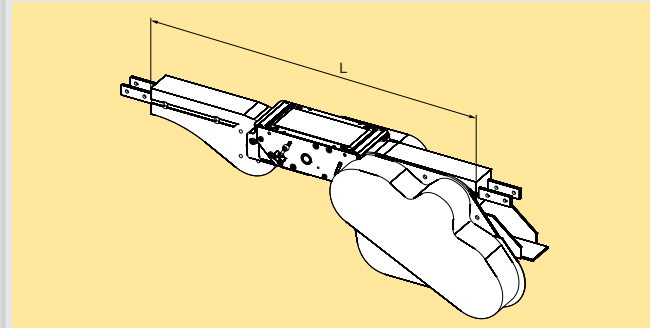

XBEB A85 HL – XBEJ A85 **8043700**
XBEB A85 HR – XBEJ A85 **8044340**
L = 818 mm

XBEB A85 HLP/HRP – XBEJ A85

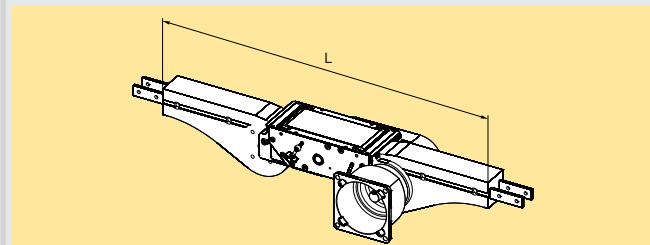

XBEB A85 HLP – XBEJ A85 **8043701**
XBEB A85 HRP – XBEJ A85 **8044341**
L = 818 mm

XBEB A85 HNLP/HNRP – XBEJ A85

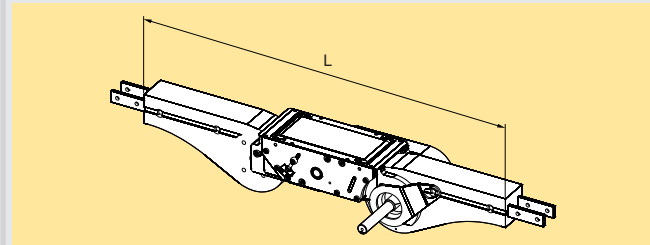

XBEB A85 HNLP – XBEJ A85 **8043702**
XBEB A85 HNRP – XBEJ A85 **8044342**
L = 818 mm

Driven belt, XH

Drive unit – machine

XHEB HL/HR – Machine

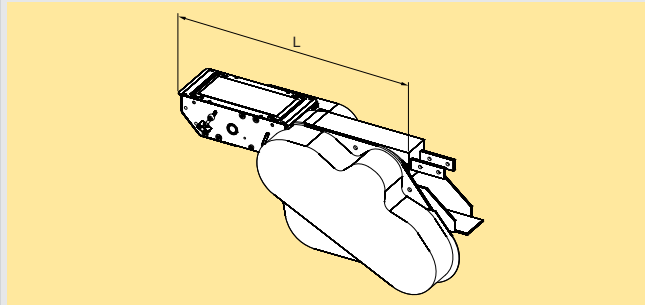

XHEB HL – Machine **8043703**
XHEB HR – Machine **8044343**
L = 544 mm

XHEB HLP/HRP – Machine

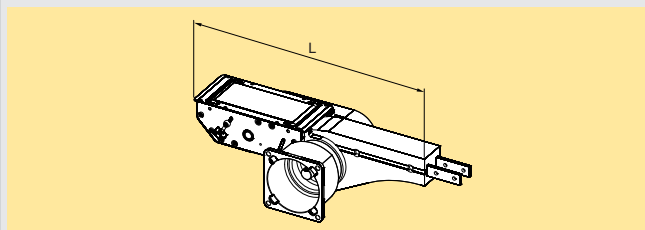

XHEB HLP – Machine **8043704**
XHEB HRP – Machine **8044344**
L = 544 mm

XHEB HNLP/HNRP – Machine

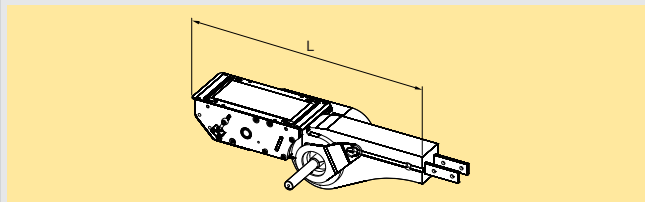

XHEB HNLP – Machine **8043705**
XHEB HNRP – Machine **8044345**
L = 544 mm

Idler unit – machine

XHEJ 325 – Machine

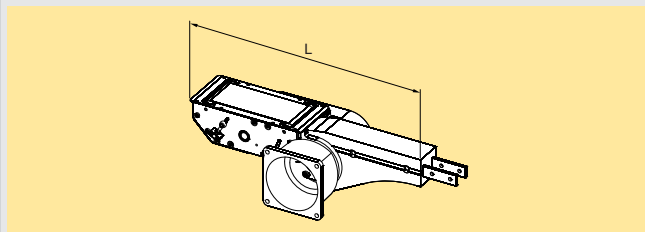

XHEJ 325 – Machine **8043706**
L = 544 mm

Drive unit – idler unit

XHEB HL/HR – XHEJ 325

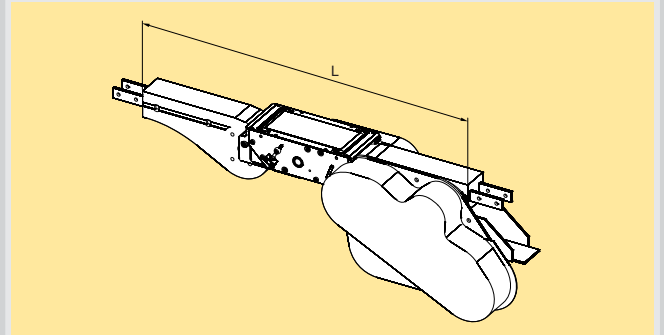

XHEB HL – XHEJ 325 **8043707**
XHEB HR – XHEJ 325 **8044346**
L = 818 mm

XHEB HLP/HRP – XHEJ 325

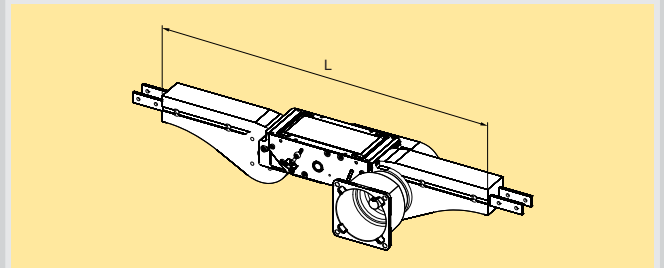

XHEB HLP – XHEJ 325 **8043708**
XHEB HRP – XHEJ 325 **8044347**
L = 818 mm

XHEB HNLP/HNRP – XHEJ 325

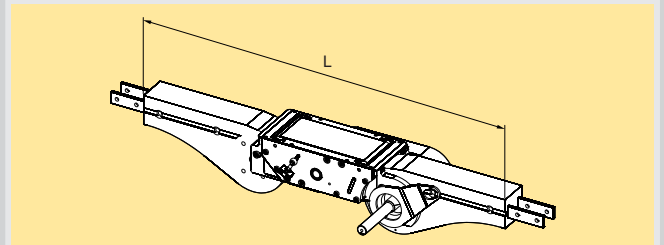

XHEB HNLP – XHEJ 325 **8043709**
XHEB HNRP – XHEJ 325 **8044348**
L = 818 mm

Driven belt, XK

Drive unit – machine

XKEB HL/HR – Machine

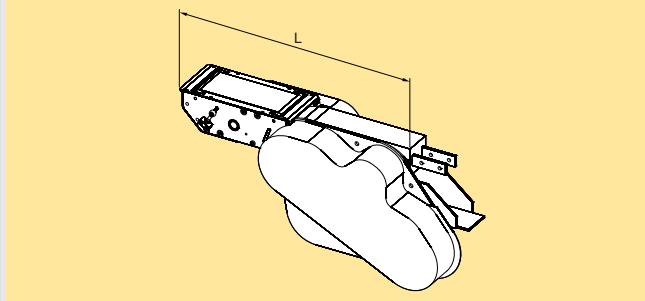

XKEB HL – Machine
XKEB HR – Machine
L = 544 mm

8043710
8044349

XKEB LP/RP – Machine

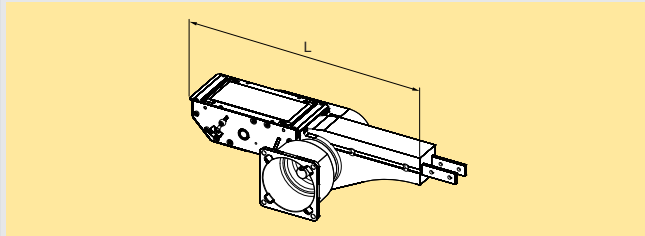

XKEB LP – Machine
XKEB RP – Machine
L = 544 mm

8043711
8044350

Idler unit – machine

XKEJ 350 – Machine

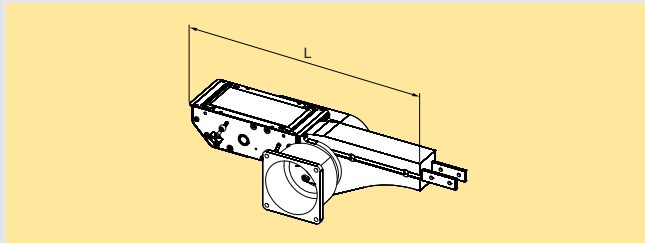

XKEJ 350 – Machine
L = 544 mm

8043712

Drive unit – idler unit

XKEB HL/HR – XKEJ 350

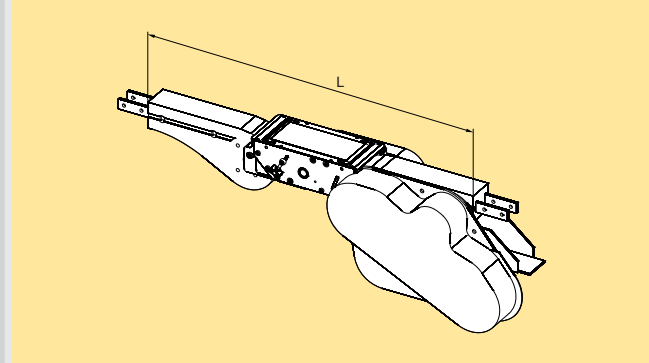

XKEB HL – XKEJ 350
XKEB HR – XKEJ 350
L = 818 mm

8043713
8044351

XKEB LP/RP – XKEJ 350

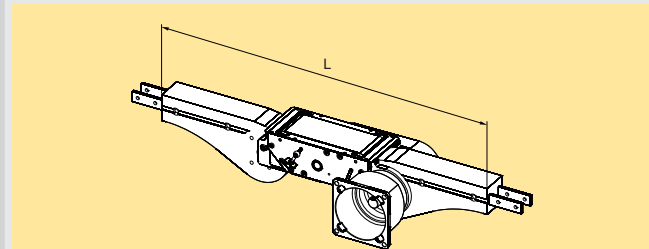

XKEB LP – XKEJ 350
XKEB RP – XKEJ 350
L = 818 mm

8043714
8044352

Spare parts

Replacement roller transfer modules

Replacement roller transfer modules, XL

Replacement roller transfer module,
left-hand transmission

For configurations 8043382,8043383,
8043344, 8043721 **8043415**

For configurations 8043385,8043386,
8043387 **8043900**

Replacement roller transfer module,
right-hand transmission

For configurations 8044301,8044302,
8044303 **8044353**

For configurations 8044304,8044305,
8044306 **8044354**

Replacement roller transfer modules, X85

Replacement roller transfer module,
left-hand transmission

For configurations 8043388, 8043389,
8043390, 8043391 **8043415**

For configurations 8043392, 8043393,
8043394 **8043900**

Replacement roller transfer module,
right-hand transmission

For configurations 8044307, 8044308,
8044309 **8044353**

For configurations 8044310, 8044311,
8044312 **8044354**

Replacement roller transfer modules, XH

Replacement roller transfer module,
left-hand transmission

For configurations 8043295, 8043396,
8043397, 8043398 **8043430**

For configurations 8043399, 8043400,
8043401 **8043427**

Replacement roller transfer module,
right-hand transmission

For configurations 8044313, 8044314,
8044315 **8044355**

For configurations 8044316, 8044317,
8044318 **8044356**

Replacement roller transfer modules, XK

Replacement roller transfer module,
left-hand transmission

For configurations 8043402, 8043403,
8043404 **8043430**

For configurations 8043405, 8043406 **8043427**

Replacement roller transfer module,
right-hand transmission

For configurations 8044319, 8044320 **8044355**

For configurations 8044321, 8044322 **8044356**

Replacement roller transfer modules, X180

Replacement roller transfer module,
left-hand transmission

For configurations 8043407,
8043723,, 8043411 **8043842**

For configurations 8043409, 8043725 **8043857**

Replacement roller transfer module,
right-hand transmission

For configurations 8044323, 8044324 **8044357**

For configurations 8044327, 8044328 **8044358**

Replacement roller transfer modules, X300

Replacement roller transfer module,
left-hand transmission

For configurations 8043408, 8043724,
8043412 **8043907**

For configurations 8043410, 8043726 **8043879**

Replacement roller transfer module,
right-hand transmission

For configurations 8044325, 8044326, **8044359**

For configurations 8044329, 8044330 **8044360**

Replacement belt transfer modules, XL and X85

Replacement belt transfer module

For configurations 8043690, 8043691,
8043692, 8043693, 8043694,
8043695, 8043696, 8043697,
8043698, 8043699, 8043700,
8043701, 8043702, 8043722 **8043792**

For configurations 8044331,8044332,
8044333, 8044334, 8044335,
8044336, 8044337, 8044338,
8044339, 8044340, 8044341,
8044342 **8044361**

Replacement belt transfer modules, XH and XK

Replacement belt transfer module

For configurations 8043703, 8043704,
8043705, 8043706, 8043707,
8043708, 8043709, 8043710,
8043711, 8043712, 8043713,
8043714 **8043793**

For configurations 8044343, 8044344,
8044345, 8044346, 8044347,
8044348, 8044349, 8044350,
8044351, 8044352 **8044362**